



# VF-T20F256开发板介绍

深圳市奥唯思科技有限公司



# CONTENTS

# 目录

01

易灵思FPGA开发板介绍

02

T20F256芯片介绍

03

VF-T20F256核心板介绍

04

VF-T20F256工程/场景介绍

05

更多产品图片



<https://www.szovs.com>

## 深圳市奥唯思科技有限公司

SHENZHEN OVS TECHNOLOGY CO.,LTD

深圳市奥唯思科技有限公司（深圳奥唯思 / SZOVS）成立于2021年，公司位于深圳南山睿园，专注于**摄像头采集**、**ISP图像处理**、**工业/内窥视觉**以及**FPGA硬件算法加速**，致力于为客户提供可快速量产、高性价比、可灵活拓展的图像解决方案。



**易灵思认证 第三方Partner**

# 01

PART



## 易灵思FPGA开发板介绍

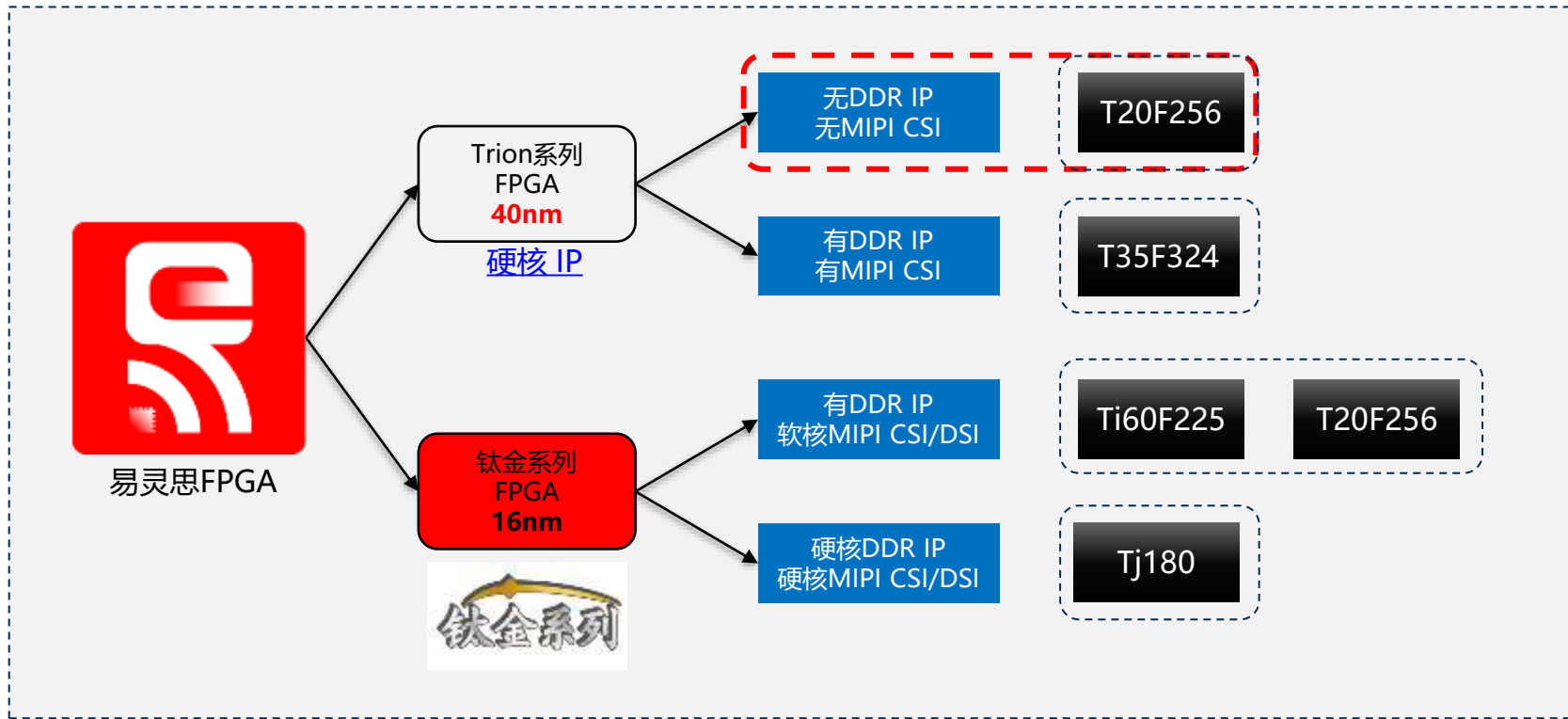



VF-Ti60F225  
易灵思**钛金**FPGA开发板



VF-T35F324  
易灵思**Trion**FPGA开发板



VF-T20F256  
易灵思**入门**FPGA开发板



VF-Ti60F100  
易灵思**超小**低功耗60K模块

型号	系列	资源	存储	DVP 相机	MIPI 相机	图像 接口	通信接口	特性描述
VF-Ti60F225	钛金	60K	DDR3	√	√	HDMI, LVDS, MIPI CSI/DSI	UART USB2.0卡	-易灵思钛金16nm FPGA -低功耗高速MIPI开发
VF-T35F324	Trion	35K	DDR3	√	√	HDMI, LVDS MIPI CSI	UART USB2.0卡	-易灵思钛金40nm FPGA -低功耗高速MIPI开发
VF-T20F256	Trion	20K	SDRAM	√		RGB HDMI子卡	UART USB2.0卡	-入门级FPGA开发板 -集成FPGA下载器
VF-Ti60F100	钛金	60K	HyperRAM 合封256Mb		√	MIPI CSI/DSI HDMI	UART	-15*15mm <b>拇指核心板</b> -60K合封256M内存MIPI应用

# 02

PART



## T20F256芯片介绍



特点	T4	T8	T13	T20	T35	T55	T85	T120
逻辑单元 (LEs)	3,888	7,384	12,828	19,728	31,680	54,195	84,096	112,128
掩模可编程存储(MPM)	✓	✓	✓	✓	—	—	—	—
嵌入式 RAM 位 (kb)	77	123	727	1,044	1,475	2,765	4,055	5,407
18x18 乘法器	4	8	24	36	120	150	240	320
锁相环 (PLLs)	1	5	5	7	7	8	8	8
最大 GPIO [1]	55	97	195	230	230	278	278	278
LVDS (TX, RX)	—	6, 6	13, 13	20, 26	20, 26	52, 52	52, 52	52, 52
DDR3, LPDDR3, LPDDR2 (1066 Mbps)	—	—	—	<del>x16</del>	x16	x32	x32	x32
内置 CSI-2 控制器的 MIPI 4Lane DPHY	—	—	2 RX 2 TX	<del>2 RX 2 TX</del>	2 RX 2 TX	3 RX 3 TX	3 RX 3 TX	3 RX 3 TX

T20F256 无DDR3/MIPI IP, T20F324才有

表 1: T20 FPGA Resources

LEs <sup>(2)</sup>	Global Clock Networks	Global Control Networks	Embedded Memory (kbits)	Embedded Memory Blocks (5 Kbits)	Embedded Multipliers
19,728	Up to 16	Up to 16	1044.48	204	36





## Features

- High-density, low-power Quantum® architecture
- Built on SMIC 40 nm process
- Core leakage current as low as 6.8 mA<sup>(1)</sup>
- FPGA interface blocks
  - GPIO
  - PLL
  - LVDS 800 Mbps per lane with up to 20 TX pairs and 26 RX pairs
  - MIPI DPHY with CSI-2 controller hard IP, 1.5 Gbps per lane
  - DDR3, LPDDR3, LPDDR2 x16 PHY with memory controller hard IP, up to 1066 Mbps
- Programmable high-performance I/O
  - Supports 1.8, 2.5, and 3.3 V single-ended I/O standards and interfaces
- Flexible on-chip clocking
  - 16 low-skew global clock signals can be driven from off-chip external clock signals or PLL synthesized clock signals
  - PLL support
- Flexible device configuration
  - Standard SPI interface (active, passive, and daisy chain)
  - JTAG interface
  - Optional Mask Programmable Memory (MPM) capability
- Fully supported by the Efinity® software, an RTL-to-bitstream compiler

表 1: T20 FPGA Resources

LEs <sup>(2)</sup>	Global Clock Networks	Global Control Networks	Embedded Memory (kbits)	Embedded Memory Blocks (5 Kbits)	Embedded Multipliers
19,728	Up to 16	Up to 16	1044.48	204	36

# 03

PART



## VF-T20F256学习板介绍

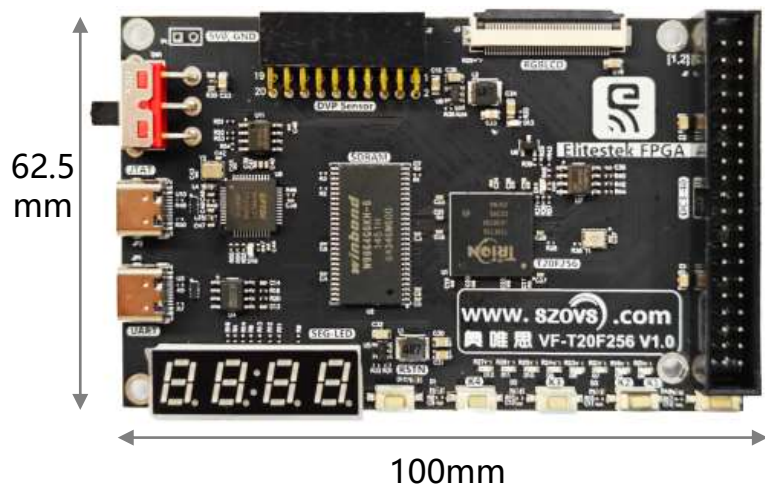

参数	描述
供应商	奥唯思 科技
核心板型号	<b>VF-T20F256开发板</b>
FPGA厂家	易灵思 (国产FPGA) 系列
FPGA型号	<b>T20F256</b>
FPGA资源	<ul style="list-style-type: none"><li>• 20K 逻辑单元, 集成SDRAM IP, <b>36个DSP</b></li><li>• 1044 kbits, 5 PLLs</li></ul>
PCB工艺	4层 1.6mm 沉金 绿色
板载芯片	<ul style="list-style-type: none"><li>• 1个25MHz有源晶振</li><li>• 1个16Mbit SPI-FLASH</li><li>• 1个64Mbit SDARM (W9864G6KH-6)</li></ul>
板载外设	<ul style="list-style-type: none"><li>• 1个TypeC USB串口</li><li>• 8个LED测试灯</li><li>• 1个硬复位, 4个FPGA复位</li><li>• 1个4位7段数码管</li><li>• 1个<b>DVP CMOS摄像头接口</b></li><li>• 1个<b>RGB LCD屏FPC接口</b> (5.5寸800*480、7寸12024*600)</li><li>• 1个DC3-40用户接口 (36 IO, 可扩USB2.0、HDMI)</li></ul>
JTAG接口	板载TypeC接口的易灵思FPGA下载器
供电	USB TypeC供电

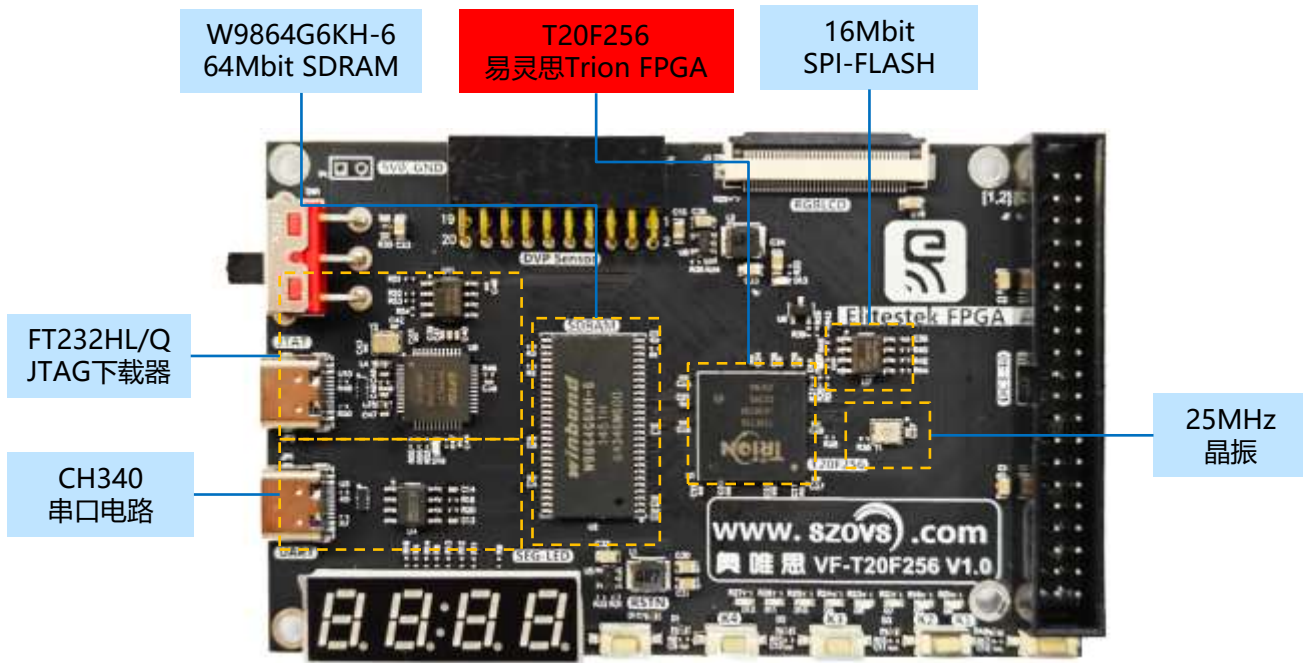

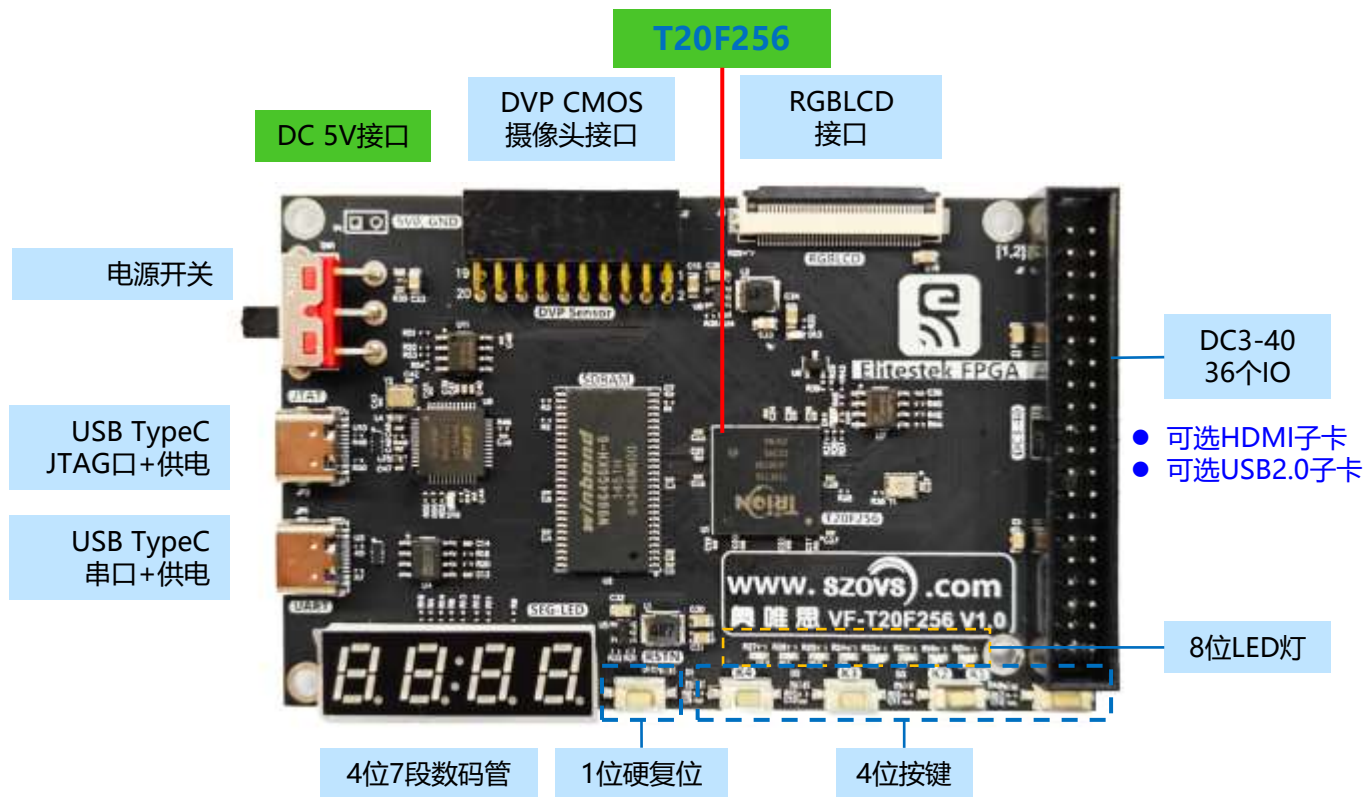



# VF-T20F256 DC3-40接口定义

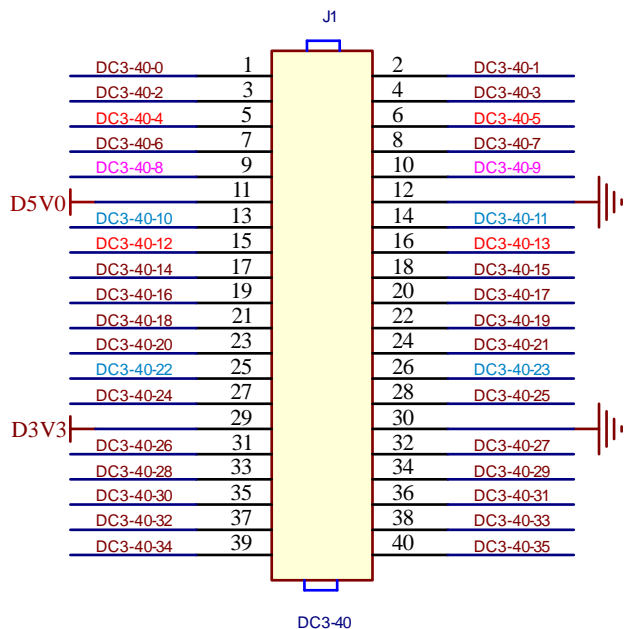

定义		DC3-40编号			定义
GPIOL_42	D0	1	2	D1	GPIOL_24_CLK0
GPIOL_35_CTRL7	D2	3	4	D3	GPIOL_27_CLK3
GPIOL_43	D4	5	6	D5	GPIOL_28_CLK4
GPIOL_55	D6	7	8	D7	GPIOL_47
GPIOL_49	D8	9	10	D9	GPIOL_67
	D5V0	11	12	GND	
GPIOL_54	D10	13	14	D11	GPIOL_60
GPIOL_56	D12	15	16	D13	GPIOL_72
GPIOL_70_CBSELO	D14	17	18	D15	GPIOR_76_PLLINO
GPIOL_73	D16	19	20	D17	GPIOL_68
GPIOR_87	D18	21	22	D19	GPIOR_86
GPIOR_85	D20	23	24	D21	GPIOR_99
GPIOR_89	D22	25	26	D23	GPIOL_66
GPIOL_71_STATUS	D24	27	28	D25	GPIOR_78
	D3V3	29	30	GND	
GPIOR_80	D26	31	32	D27	GPIOR_79
GPIOR_82	D28	33	34	D29	GPIOR_84
GPIOR_83	D30	35	36	D31	GPIOR_93
GPIOR_95	D32	37	38	D33	GPIOR_97
GPIOR_90	D34	39	40	D35	GPIOR_92

# 04

PART



## VF-T20F256 工程&场景介绍



序号	工程名	设计描述
0	00_T20F256_FLASH_Loader	VF_T20F256 SPI-FLASH桥接工程 (仅固化用bit)
1	01_LED_8bit_Addr_Test	板载8bit LED自加工程
2	02_LED_8bit_Water_Test	板载8bit LED流水灯工程
3	03_KEY_4bit_Test	板载4bit按键测试工程
4	04_SEG_4bit_Test	板载4bit数码管测试工程
5	05_UART_115200_Test	板载UART串口115200波特率测试工程
6	06_RGBLCD_800480_Test	800*480 RGBLCD驱动工程
7	07_SDRAM_LCD_800480_Test	基于SDRAM读写的800*480 LCD显示工程
8	08_MT9M001_800480_Test	基于MT9M001摄像头的实时显示系统(1280*1024 crop到800*480)
9	09_OV5640_800480_Test	基于OV5640摄像头的实时采集显示系统(800*480)
10	10_MT9V034_800480_Test	基于MT9V034摄像头的实时采集显示系统(752*480填充显示于800*480)
11	11_AR0135_800480_Test	基于AR0135摄像头的实时采集显示系统(1280* 720 crop到800*480)
12	12_SC1336_800480_Test	基于SC1336摄像头的实时采集显示系统(1280*720 crop到800*480)

◆ 同时根据采购选型，可提供基于7寸1024\*600 LCD的工程，以及基于配套HDMI子卡的工程





- DVP CMOS模组, 支持
- 130万彩色MT9M001
  - 500万彩色OV5640
  - 30万黑白MT9V034
  - 130万黑白AR0135
  - 130万彩色SC1336

- 5.5寸800\*480 RGBLCD
- 7寸1024\*600 RGBLCD

- HDMI1.4输出子卡
- 最高支持1080P60

VF-T20F256  
易灵思FPGA  
学习板

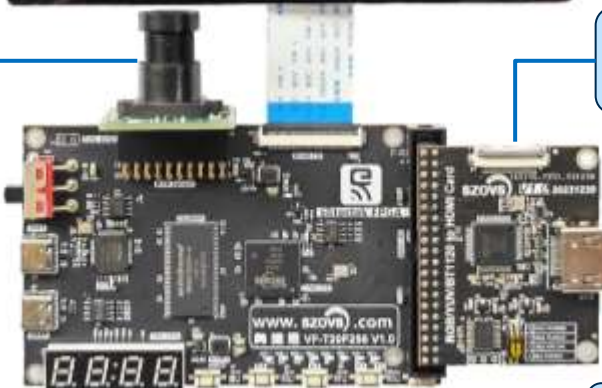

- USB2.0子卡
- 提供PC Demo

# 05

PART



**更多图片**



更多VF-T20F256图片



深圳奥唯思，为FPGA图像而生.....



奥唯思 官方公众号

官方网站: [www.szovs.com](http://www.szovs.com) (资料下载)

官方淘宝: [szovs.taobao.com](http://szovs.taobao.com)

**“奥唯思FPGA”** 店铺

FPGA论坛: [www.crazyfpga.com](http://www.crazyfpga.com)

FPGA交流群: [851598171](https://t.me/851598171) (QQ)